

## NORTH AMERICAN STANDARD INSPECTION PROCEDURE

### 1. PREPARE THE VEHICLE AND DRIVER

Instruct the driver to remain at the controls, and turn the engine off. (Allow cool down time for turbo-charged engines.) Place chock blocks in position beginning on the driver's side, one in front, and one behind the driver axle tires or between the axles, and advise the driver that the wheels have been chocked.

Have the driver place the transmission in neutral and release all brakes.

Advise the driver in the use of hand signals. (Lamps and brakes.)

### 2. CHECK DRIVER'S REQUIREMENTS

- **DRIVER LICENSE (391.11)**  
Check for expiration date, birth date, status check.
- **MEDICAL CERTIFICATE (391.41)**  
Check for expiration date, corrective lenses, hearing aid, signatures. Canadian driver license services as medical certificate.
- **MEDICAL WAIVER (if applicable) (391.49)**  
Check for expiration date, and make sure form is completed. Note the stated physical limitations.
- **RECORD OF DUTY STATUS (395.8) (395.3)**  
Updated to last change of duty status, today's date, legible handwriting, past 7 days recorded, mileage, driving time, on duty time, vehicle numbers, carrier name, signature.  
"Remarks" section may include locations of duty status change, unusual circumstances that delay the trip, and shipping document numbers or the name of the shipper. Check for written authorization for interactive electronic recording devices, if applicable.
- **DRIVER VEHICLE INSPECTION REPORT (396.11)**  
Check for I.D. number of vehicle(s) inspected, record of defects found (if any), and signatures.
- **SHIPPING PAPERS/BILL OF LADING**  
Check for listings of hazardous materials indicated by the first entry, an "X" in the H.M. column, or a contrasting color. Papers must be within arm's reach and visible.
- **SEAT BELT (392.16)**  
Check for condition and usage
- **ALCOHOL AND DRUGS (392.4) (392.5)**  
Check for violations

### 3. CHECK FOR PRESENCE OF HAZARDOUS MATERIALS

- **PLACARDS**  
Check for the presence of placards, but use caution even if none are posted.
- **LEAKS, SPILLS, UNSECURE CARGO**  
When hazardous materials are present, be **ESPECIALLY** careful with leaks, spills, or unsecure cargo.
- **MARKINGS**  
Cargo tanks and portable tanks will display markings on an orange panel or placard. They indicate the I.D. number of the hazardous materials. There are exceptions to this rule.
- **LABELS**  
When containers are visible, labels will identify the hazardous materials. There are exceptions to this rule.

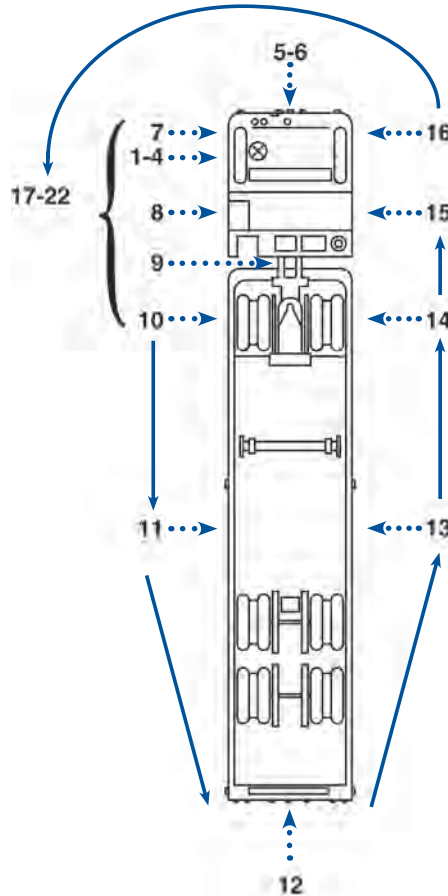

### 4. INSIDE CAB

- **STEERING LASH**  
Measure amount of steering lash and compare with Out-of-Service Criteria.
- **STEERING COLUMN**  
Check for unsecure attachment.

### 5. FRONT OF TRACTOR

- **HEAD LAMPS, TURN SIGNALS, EMERGENCY FLASHERS (393.25)**  
Check for improper color and operation.
- **WINDSHIELD WIPERS (393.78)**  
Check for improper operation. Two wipers are required unless one can clean the driver's field of vision.
- **WINDSHIELD (393.60)**  
Check for cracks or other damage. Check for decals or stickers in field of vision.

### 6. STEERING AXLE

**INFORM THE DRIVER THAT YOU ARE GOING UNDER THE VEHICLE, AND TO LISTEN FOR YOUR INSTRUCTIONS.**

- **STEERING SYSTEM (BOTH SIDES) (393.209)**  
Check for loose, worn, bent, damaged or missing parts. Instruct the driver to rock the steering wheel, and check key components: front axle beam, gear box, pitman arm, drag link, tie rod, tie rod ends.
- **FRONT SUSPENSION (BOTH SIDES) (393.207)**  
Check for indications of misaligned, shifted, or cracked springs, loosened shackles, missing bolts, springhangers unsecure at frame, and cracked or loose U-bolts. Also, check for

unsecure axle positioning parts and signs of axle misalignment.

- **FRONT BRAKES (BOTH SIDES) (393.48)**  
Check for missing, nonfunctioning, loose, contaminated, or cracked parts on the brake system, such as brake drum, shoes, rotors, pads, linings, brake chamber, chamber mounting push rods, slack adjusters.  
Check for "S" cam flip over. Be alert for audible air leaks around brake components and lines.  
With the brakes released, mark the brake chamber push rod at a point where the push rod exits the brake chamber. Mark the push rods on both sides at this time; all push rods will be measured in ITEM 10.
- **FRONT AXLE**  
Check for cracks, welds, and obvious misalignment.
- **FRAME and FRAME ASSEMBLY**  
Check for cracks, or any defect that may lead to the collapse of the frame.

### 7. LEFT FRONT SIDE OF TRACTOR (393.205)

- **LEFT FRONT WHEEL & RIM**  
Check for cracks, unseated locking rings, broken or missing lugs, studs or clamps. Bent or cracked rims, "bleeding" rust stains, loose or damaged lug nuts and elongated stud holes.
- **LEFT FRONT TIRE (393.75)**  
Check for improper inflation, serious cuts, bulges.  
Check tread wear and measure major tread groove depth.  
Inspect sidewall for defects.  
Check for exposed fabric or cord.  
Radial and bias tires should not be mixed on the steering axle.

### 8. LEFT SADDLE TANK AREA

- **LEFT FUEL TANK(S) (393.65)**  
Check for unsecure mounting, leaks, or other damage. Verify that the fuel cross-over line is secure. Check for unsecure cap(s).  
Check ground below tank for signs of leaking fuel.
- **TRACTOR FRAME (393.201)**  
Check frame rails and cross members on the tractor just behind the cab, looking for cracks, bends, or excessive corrosion.
- **EXHAUST SYSTEM (393.83)**  
Check for unsecure mounting, leaks (under the cab), exhaust contacted by fuel or air lines or electrical wires.

### 9. TRAILER FRONT

- **AIR & ELECTRICAL LINES (393.28)**  
Lines between tractor and trailer should be suspended and free of tangles and crimps. They should have sufficient slack to allow the vehicle to turn. Inspect line connections for proper seating. Listen for audible air leaks.
- **FRONT END PROTECTION (393.106)**  
Check for height requirements. (Note exceptions.)

### 10. LEFT REAR TRACTOR AREA (393.205)

- **WHEELS, RIMS & TIRES**  
Inspect as described in ITEM 7.  
Check inside tire of dual for inflation and general condition.  
Tires should be evenly matched (same

circumference) on dual wheels. Without placing yourself between the tires on tandem axles, check for debris between the tires.

- **LOWER FIFTH WHEEL (393.70)**  
Check for unsecure mounting to the frame or any missing or damaged parts. Check for any visible space between the upper and lower fifth wheel plates. Verify that the locking jaws are around the shank and not the head of the kingpin. Verify that the release lever is sealed properly, and that the safety latch is engaged.
- **UPPER FIFTH WHEEL (393.70)**  
Check for any damage to the weight bearing plate and its supports on the trailer. Check kingpin condition.
- **SLIDING FIFTH WHEEL**  
Check for proper engagement of locking mechanism (teeth fully engaged on rail). Check for worn or missing parts, making sure that the position does not allow the tractor frame rails to contact the landing gear during turns.

**INFORM THE DRIVER THAT YOU ARE GOING UNDER THE VEHICLE. ENTER THE UNDERCARRIAGE IN VIEW OF THE DRIVER.**

- **SUSPENSION (BOTH SIDES) (393.207)**  
Inspect as described in ITEM 6. Check for deflated or leading air suspension systems.
- **BRAKES (BOTH SIDES) (393.48)**  
Inspect brakes as described in ITEM 6. With brakes released, mark the push rods.

#### 11. LEFT SIDE OF TRAILER

- **FRAME AND BODY (393.20, 393.203)**  
Check for cracks and any indication leading to collapse of the frame.
- **CARGO SECUREMENT (393.100)**  
Check for improper blocking or bracing, and unsecure chains or straps. Verify end gates are secured in stake pockets. Check tarp or canvas.
- **WHEELS, RIMS, & TIRES (393.205)**  
Inspect as described in ITEM 7.
- **SLIDING TANDEM (393.70)**  
Check for misalignment and position. Look for damaged, worn, or missing parts. Check locking mechanism; teeth of locking mechanism must fully mesh with those of the rail secured to the frame.

**INFORM THE DRIVER THAT YOU ARE GOING UNDER THE VEHICLE. ENTER THE UNDERCARRIAGE IN VIEW OF THE DRIVER.**

- **SUSPENSION (BOTH SIDES) (393.207)**  
Inspect as described in ITEM 6
- **BRAKES (BOTH SIDES) (393.48)**  
Inspect as described in ITEM 6. With brakes released, mark push rods.

#### 12. REAR OF TRAILER

- **TAIL, STOP & TURN LAMPS & EMERGENCY FLASHERS (393.11)**  
Check for improper color and operation.
- **CARGO SECUREMENT (393.100)**  
Inspect as described in ITEM 11. Also check tailboard security. Verify end gates are secured in stake pockets, and rear doors are closed. Check both sides of trailer to insure protection of cargo from shifting or falling.

#### 13. RIGHT SIDE OF TRAILER

- CHECK ALL ITEMS AS ON LEFT SIDE.

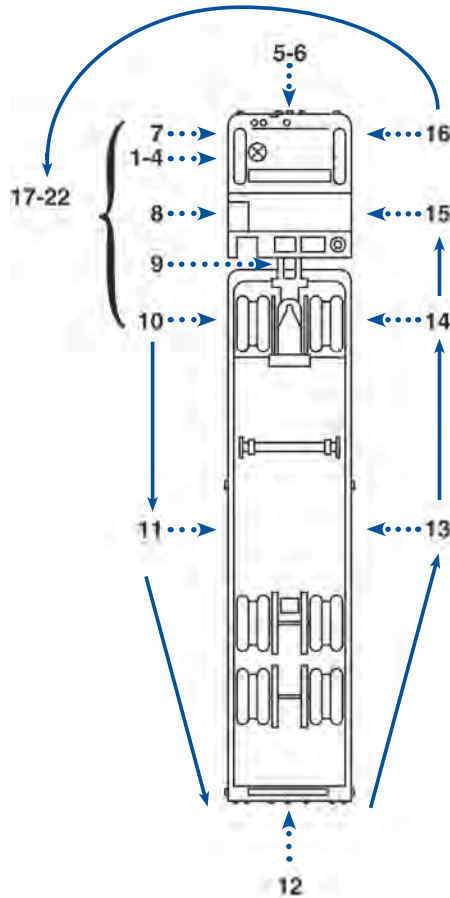

#### 14. RIGHT REAR TRACTOR AREA

- CHECK ALL ITEMS AS ON LEFT SIDE.

#### 15. RIGHT SADDLE TANK AREA

- CHECK ALL ITEMS AS ON LEFT SIDE.

#### 16. RIGHT FRONT SIDE OF TRACTOR

- CHECK ALL ITEMS AS ON LEFT SIDE.

#### 17. BRAKE ADJUSTMENT CHECK

**INFORM THE DRIVER THAT YOU ARE GOING UNDER THE VEHICLE. ENTER THE UNDERCARRIAGE IN VIEW OF THE DRIVER.**

- **MEASURE PUSH ROD TRAVEL (ALL BRAKES) (393.48)**  
While the brakes are applied, move around the vehicle and measure the distance of push rod travel at each chamber. Write down each push rod measurement, and compare them to the Out-of-Service Criteria for the appropriate size and type of brake chamber. Again, listen for leaks as you move around the vehicle.

#### 18. FIFTH WHEEL MOVEMENT CHECK (393.70)

- **USE CAUTION**  
If conducted improperly, this method of checking for fifth wheel movement can result in serious damage to the vehicle. Use caution and instruct the driver carefully.
- **PREPARE THE VEHICLE AND DRIVER**  
Have the driver put the vehicle in gear, release the service brakes, and apply the trailer brakes. Remove the wheel chocks and have the driver start the vehicle. Carefully explain the procedure to the driver. Tell the driver to GENTLY rock the tractor as you watch the fifth wheel.

- **CONDUCT THE PROCEDURE**  
As the tractor rocks, watch for movement between the mounting components and frame, pivot pin and bracket, and the upper and lower fifth wheel halves.

#### 19. AIR LOSS RATE (393.50)

- **WHEN TO CONDUCT THE TEST**  
If you heard an air leak at any point in the inspection, you should now check the vehicle's air loss rate.
- **CONDUCT THE PROCEDURE**  
Have the driver run the engine at idle, then apply and hold the service brake. Observe the air reservoir pressure gauge on the dash. Have driver pump the pressure down to 80 psi. Compressors do not activate until system pressure drops below a certain level. At about 80 lbs most compressors should be operating. Air pressure should be maintained or increase. A drop in pressure indicates a serious air leak in the brake system, and the vehicle should be placed out of service.

#### 20. LOW AIR PRESSURE WARNING DEVICE (393.51)

- **TEST THE WARNING DEVICE**  
Instruct the driver to pump the air down until the low air pressure warning device activates. Observe the gauges on the dash. The low air pressure warning must activate at a minimum of 1/2 the compressor governor cut out pressure, approximately 55 psi.

#### 21. TRACTOR PROTECTION VALVE

This procedure will test both the tractor protection valve and the trailer emergency brakes.

- **CONDUCT THE TEST**  
Instruct the driver to release the emergency brakes by pushing in the dash valves. Break the supply emergency line at the hose couplers between the tractor and the trailer. When the line is disconnected, a blast of air will be noticed. At this point, the emergency brakes on the trailer should set up.
- **OBSERVE THE DASH GAUGE**  
Air will leak from the tractor side of the line until the pressure in the tractor's system drops to the 20-45 psi range. At that point, the air loss should stop, isolating the tractor air system. A loss of air in the tractor system below the 20-45 psi range indicates a malfunctioning tractor protection valve. If the trailer brakes do not set up when the line is disconnected, there is a problem with the trailer emergency brakes.

#### 22. COMPLETE THE INSPECTION

- **COMPLETE PAPER WORK**  
Complete inspection forms and other paperwork, as required.
- **CONCLUDE WITH THE DRIVER**  
Explain any violations or warnings to the driver. Take appropriate enforcement action, if necessary.
- **APPLY C.V.S.A. DECAL**  
Apply a C.V.S.A. decal on all vehicles that qualify.